

Block Diagram of Baseband (Version: 3.5 ; Edit : 167) for layout version 15

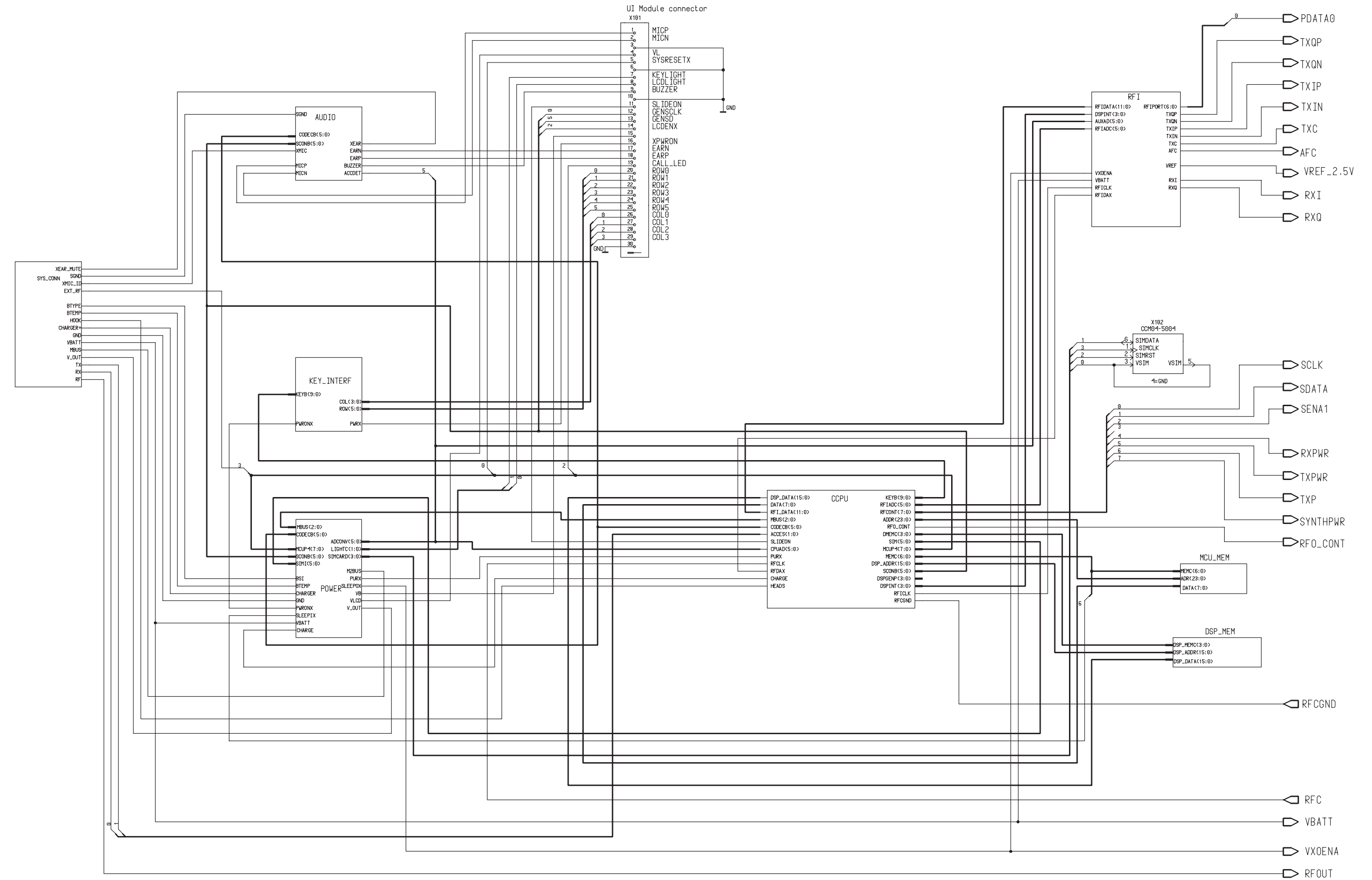

Circuit Diagram of Power Supply & Charging (Version: 3.5 ; Edit:126) for layout version 15

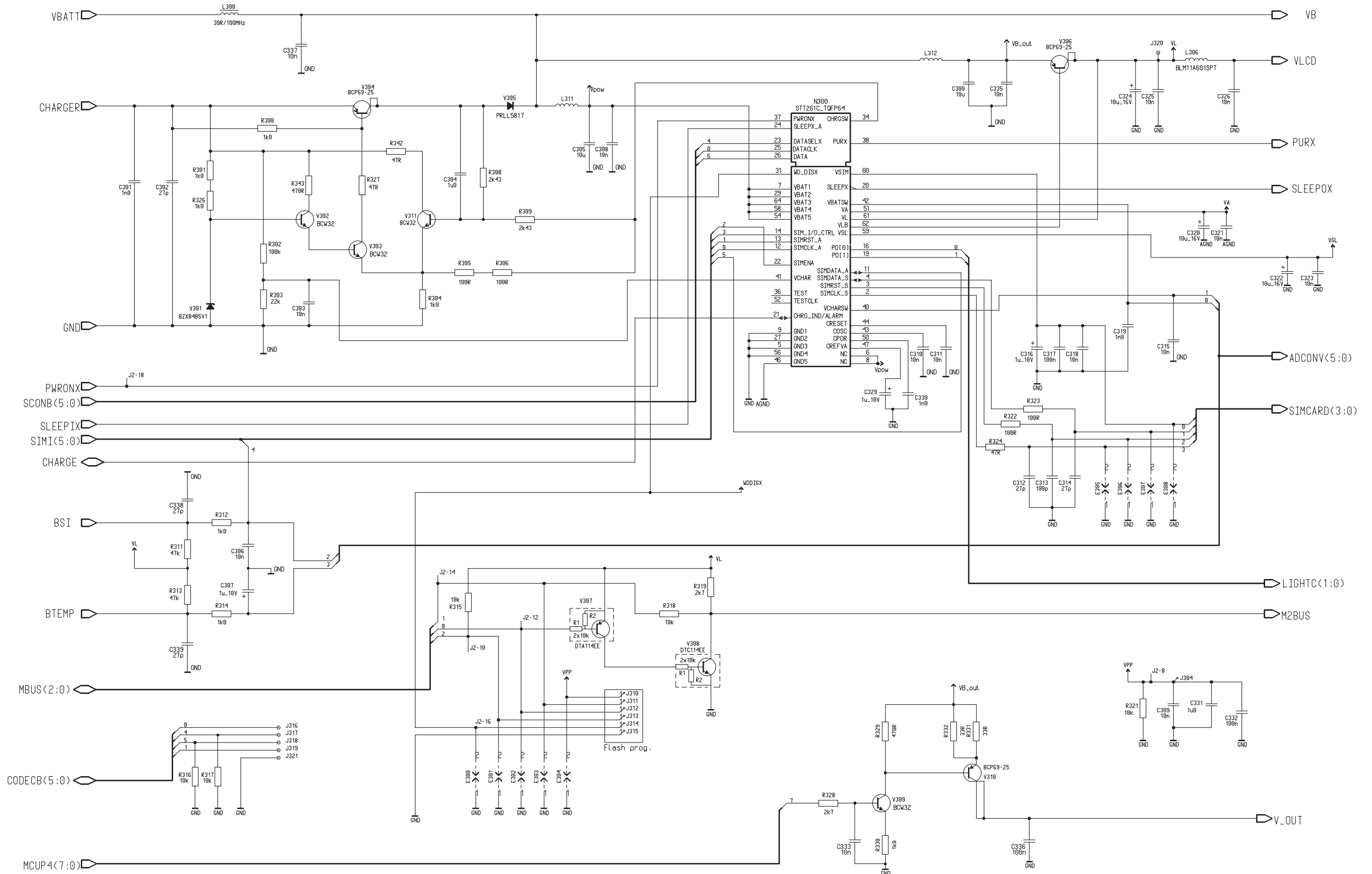

Circuit Diagram of Central Processing Unit (Version: 3.5 ; Edit 145) for layout version 15

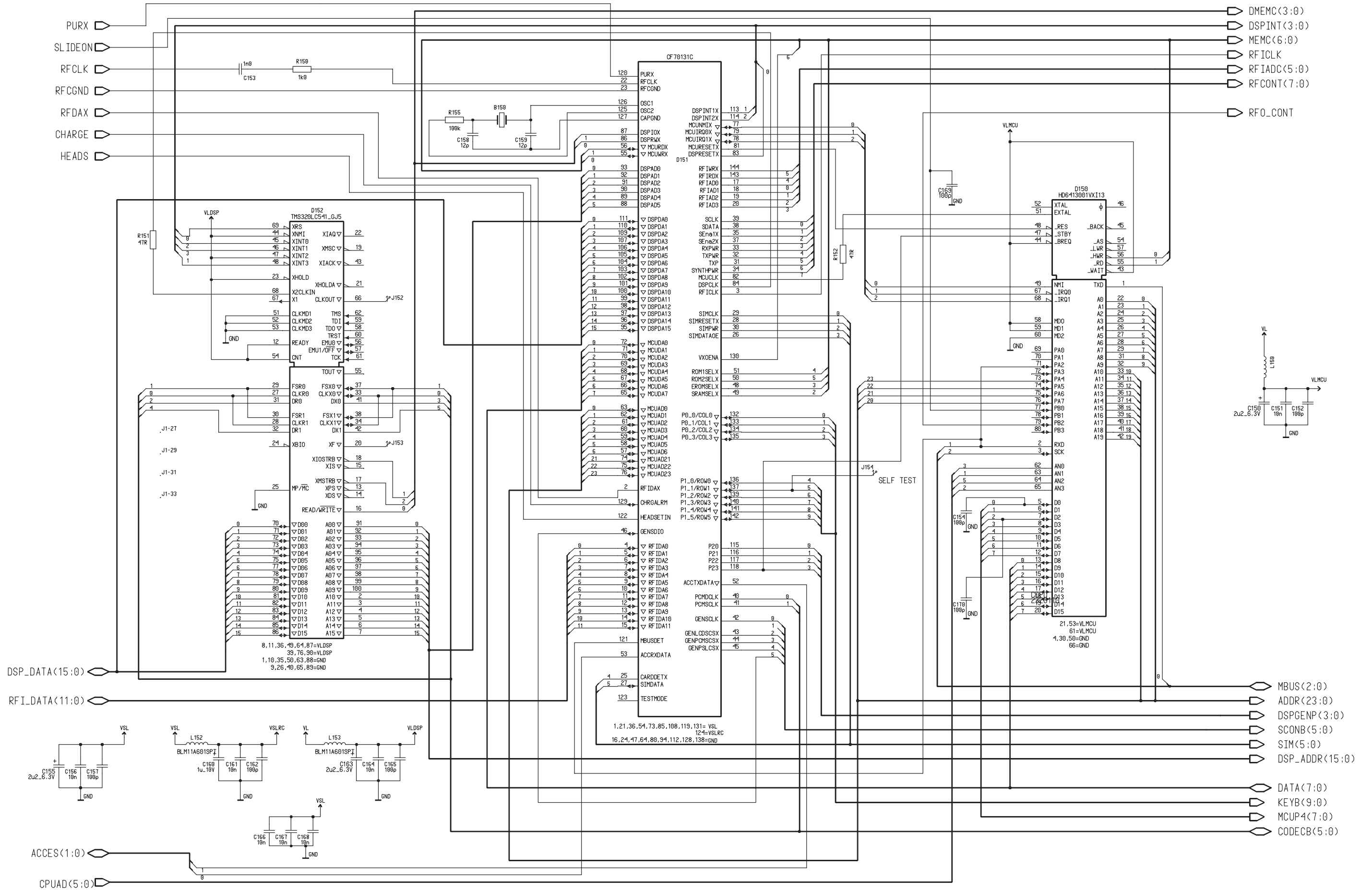

Circuit Diagram of MCU Memory Block (Version: 3.5 ; Edit 53) for layout version 15

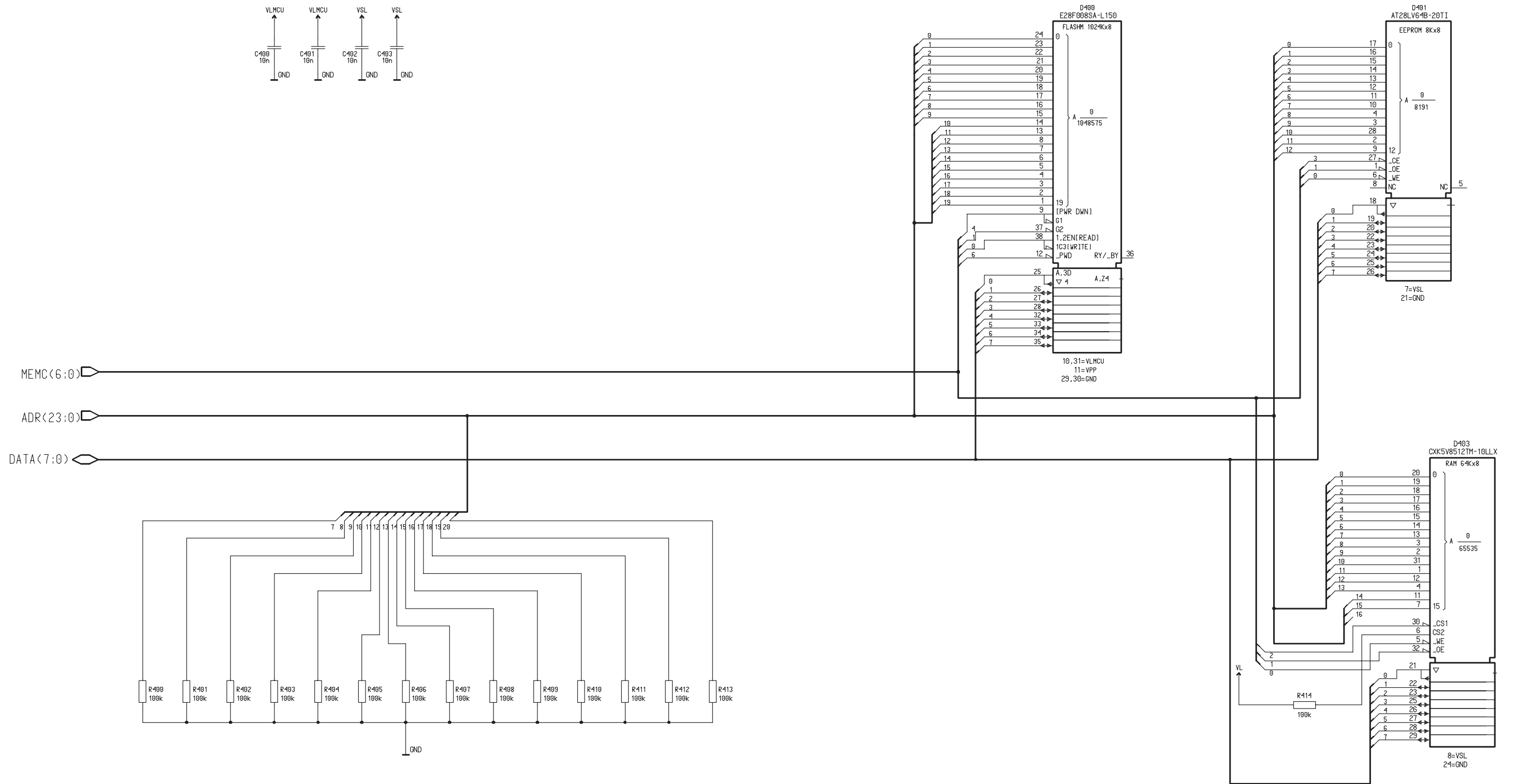

Circuit Diagram of Keyboard and Display Interface (Version: 3.5 ; Edit 45) for layout version 15

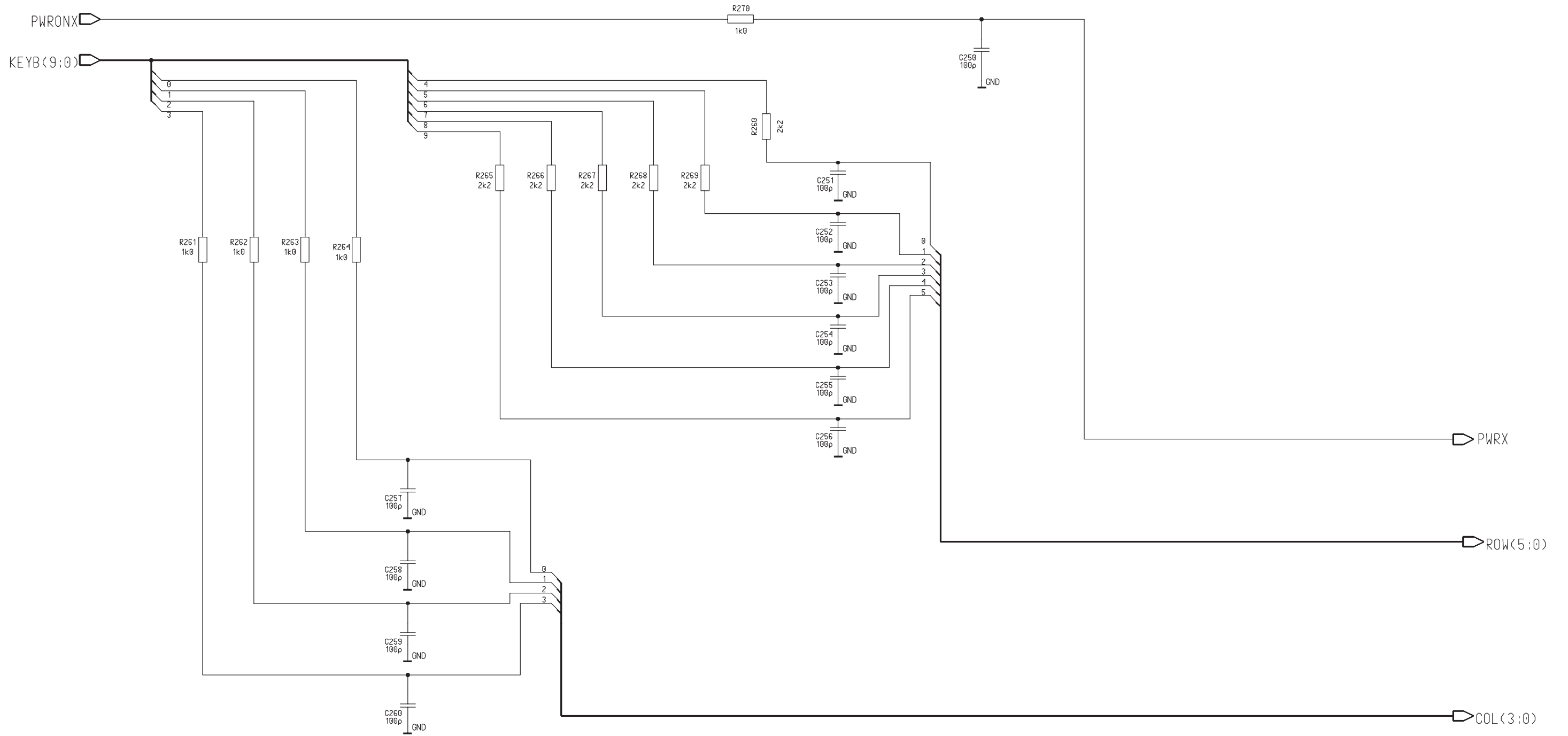

Circuit Diagram of Audio (Version: 3.5 ; Edit 84) for layout version 15

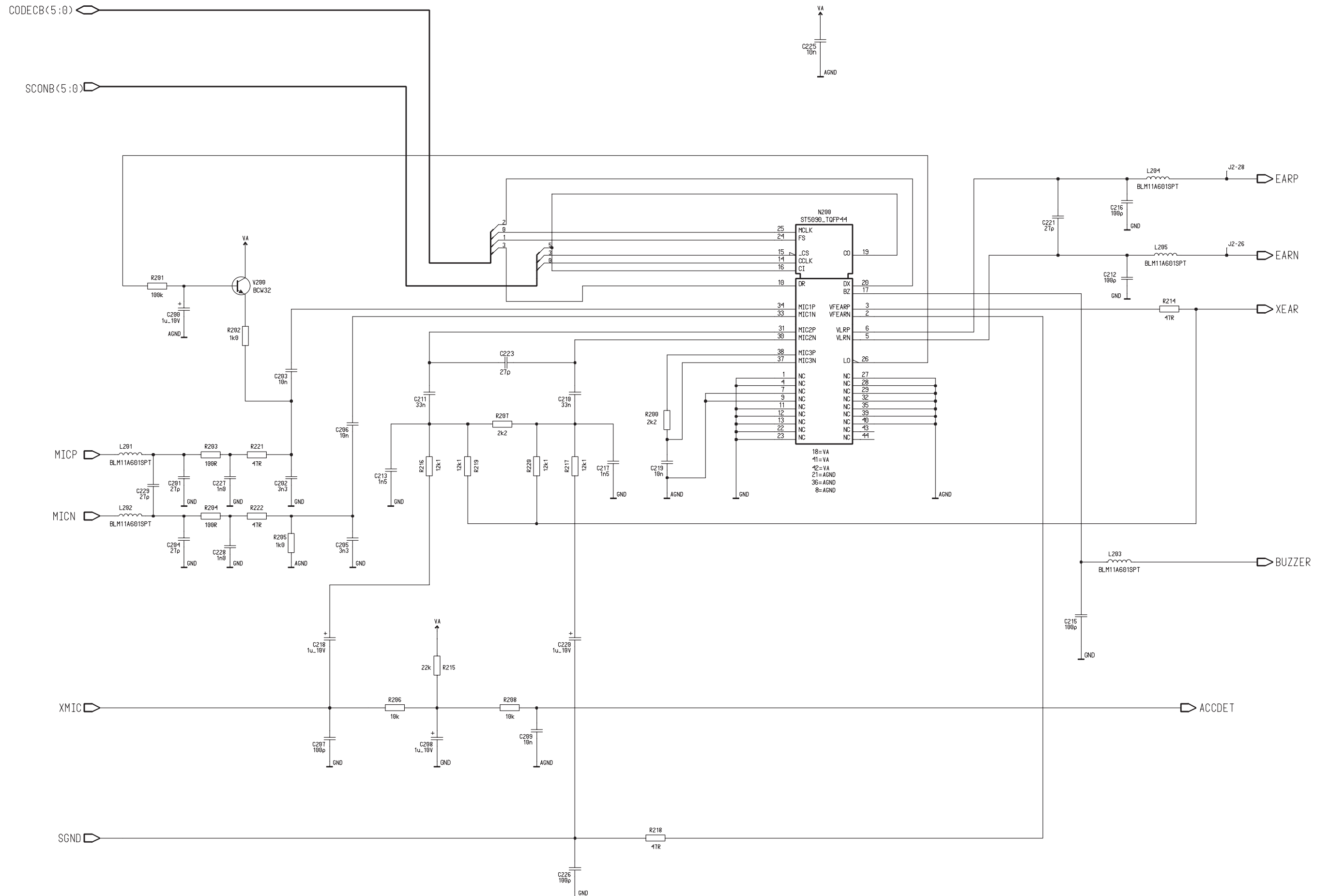

Circuit Diagram of DSP Memory Block (Version: 3.5 ; Edit 45) for layout version 15

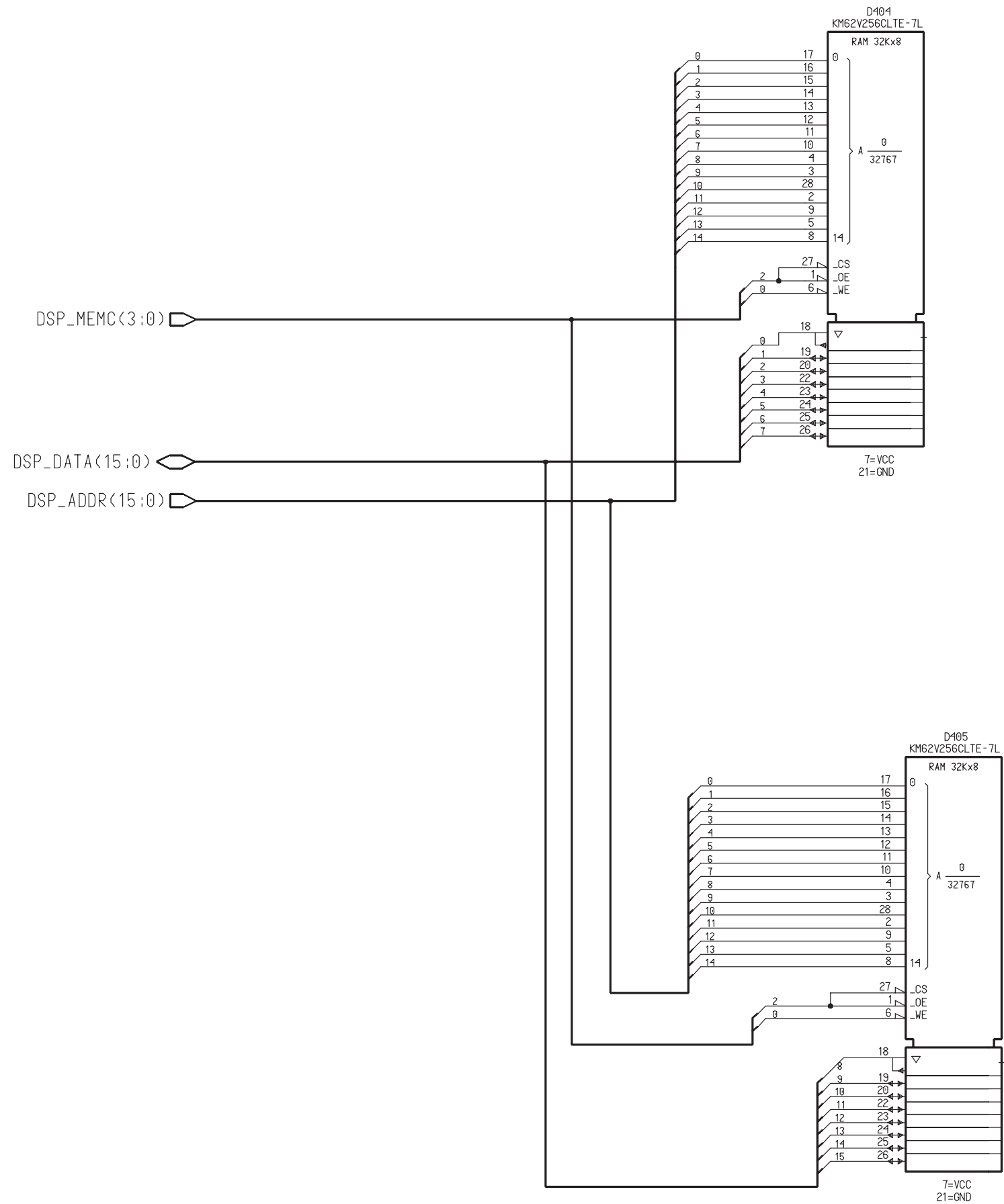
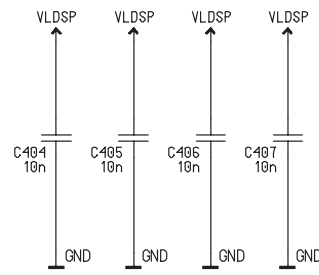

Circuit Diagram of RFI (Version: 3.5 ; Edit 92) for layout version 15

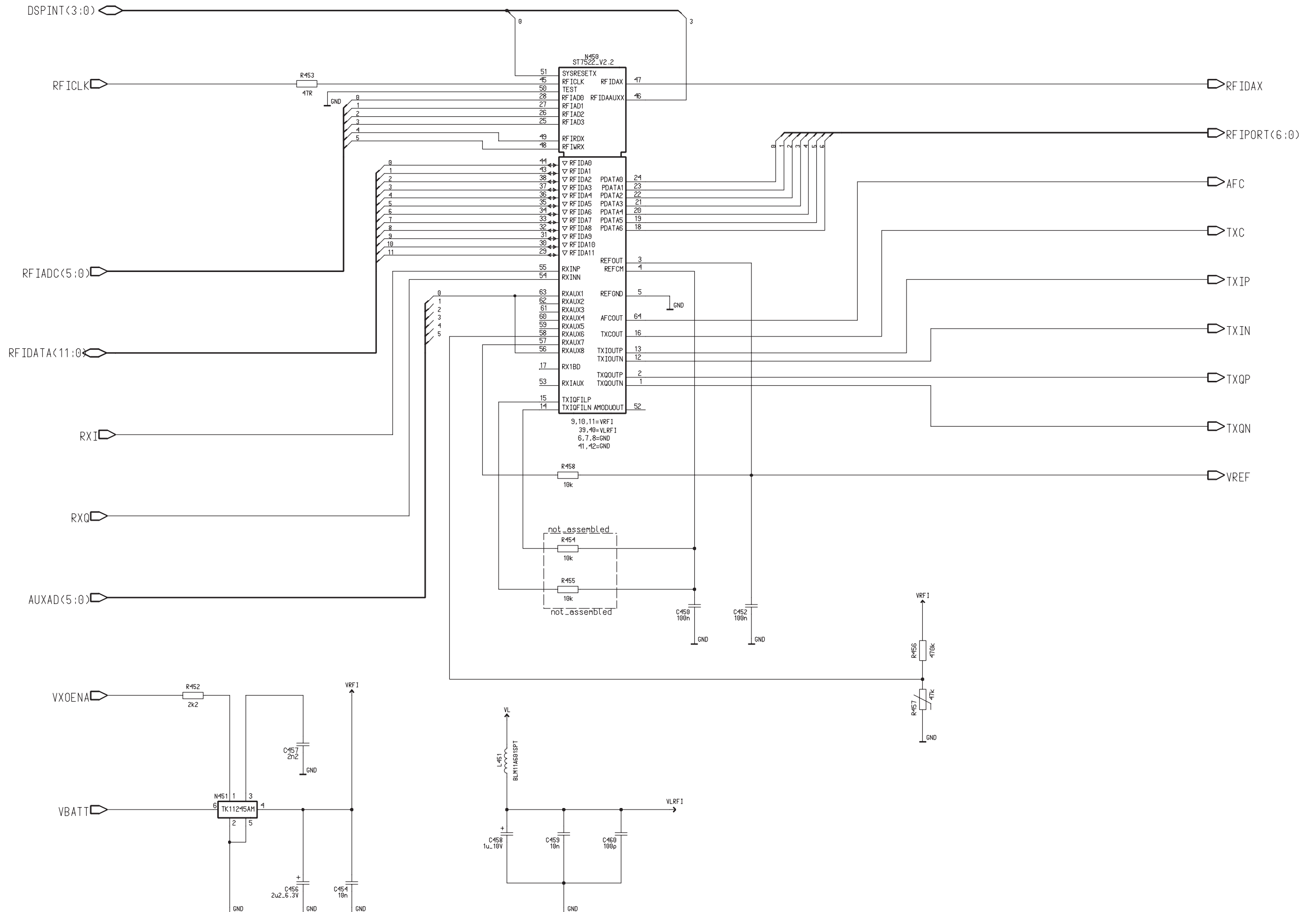

Circuit Diagram of Receiver (Version: J4.2 ; Edit 336) for layout version 15

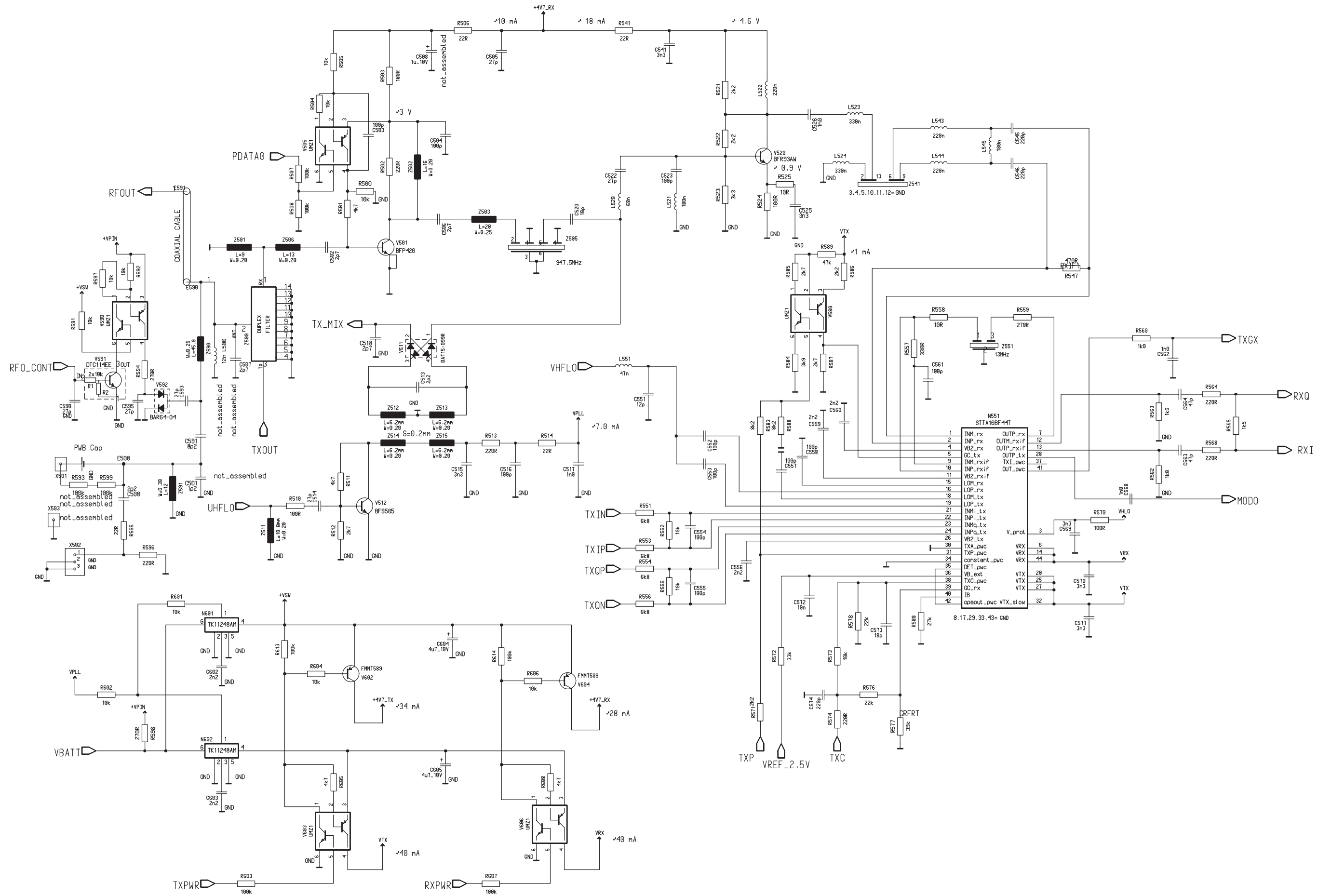

Circuit Diagram of Transmitter (Version: J4.2 ; Edit 350) for layout version 15

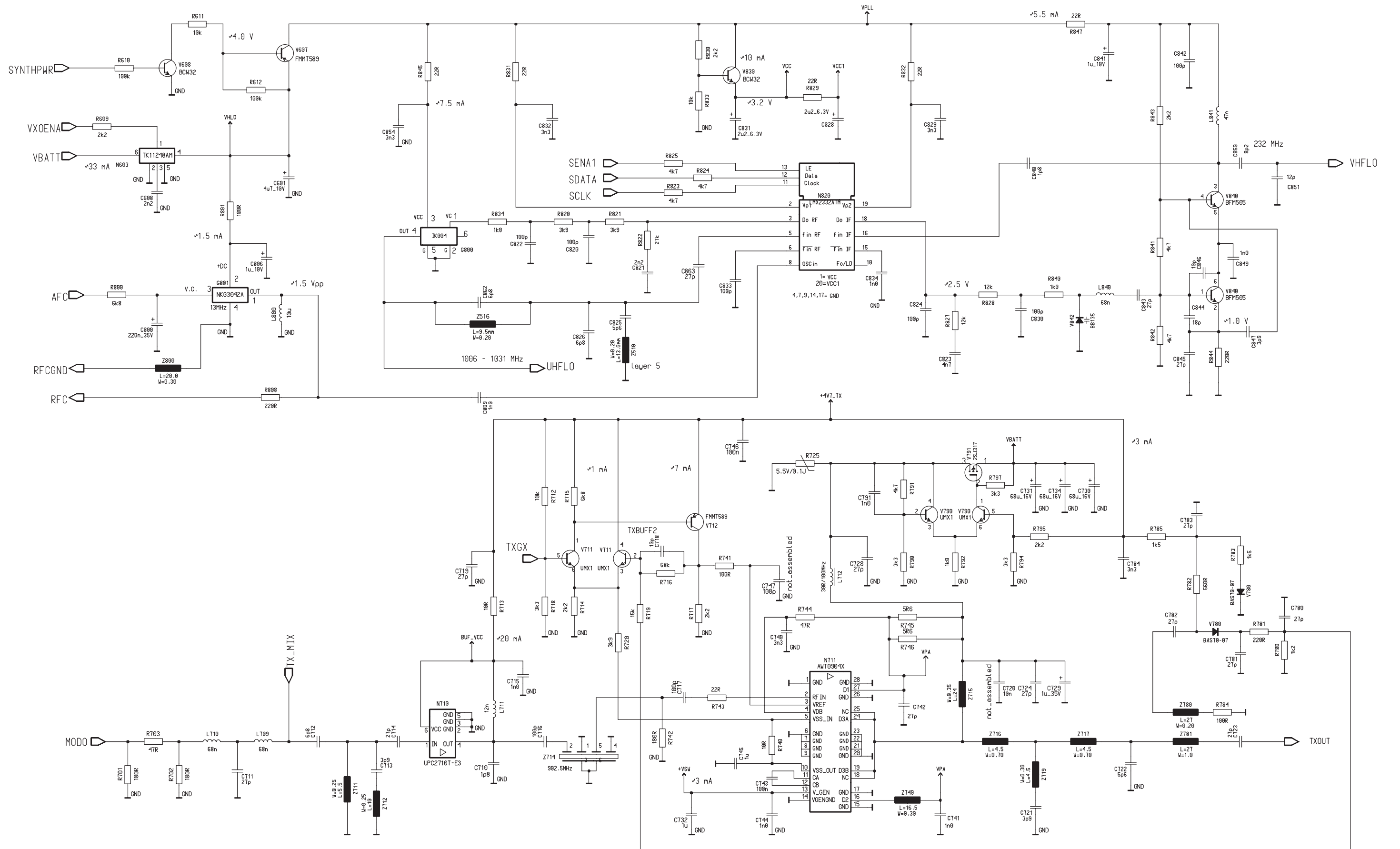

Circuit Diagram of System Connector (Version: 3.5 ; Edit 94) for layout version 15

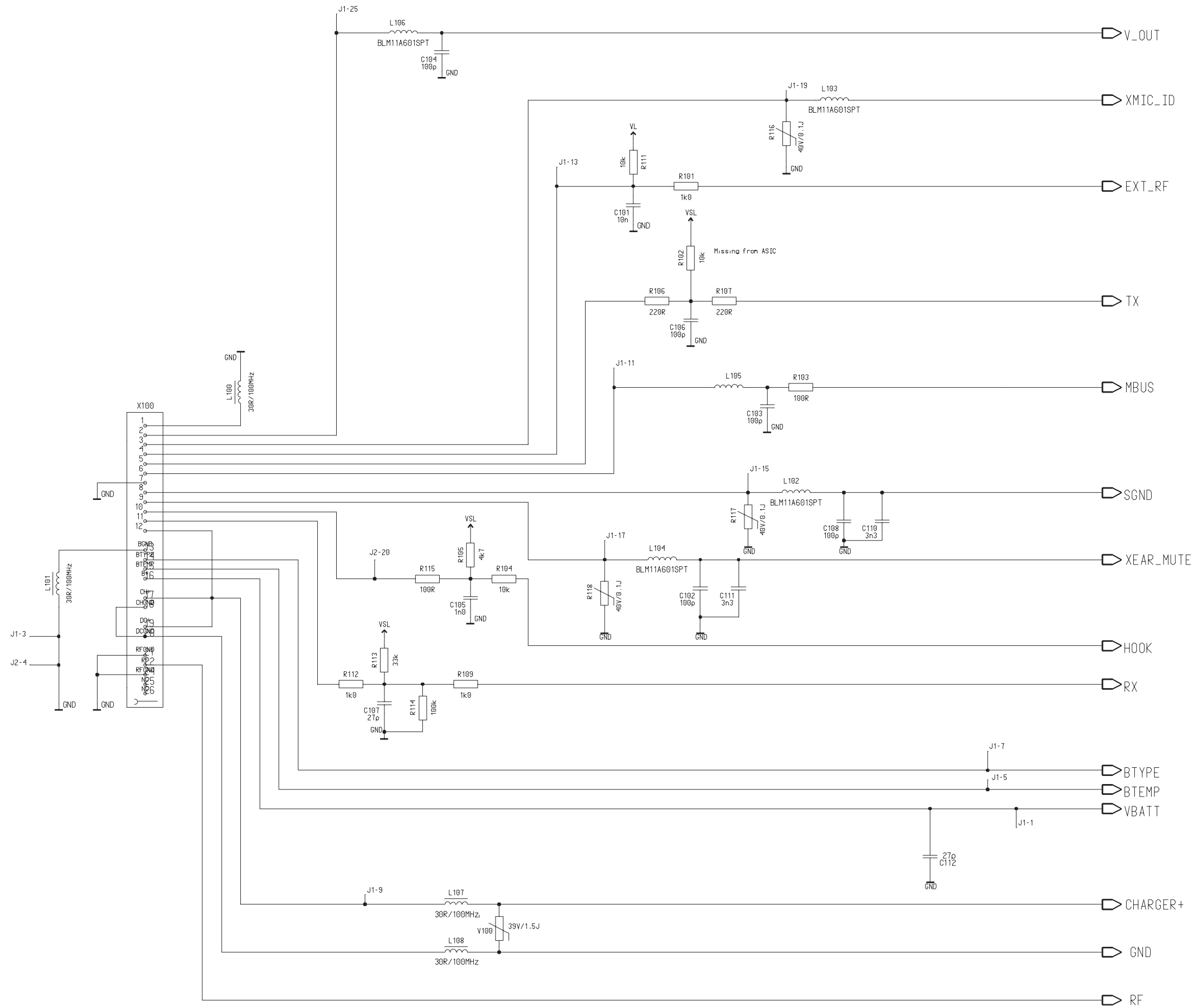

Layout Diagrams of GJ8 (Version: 15)

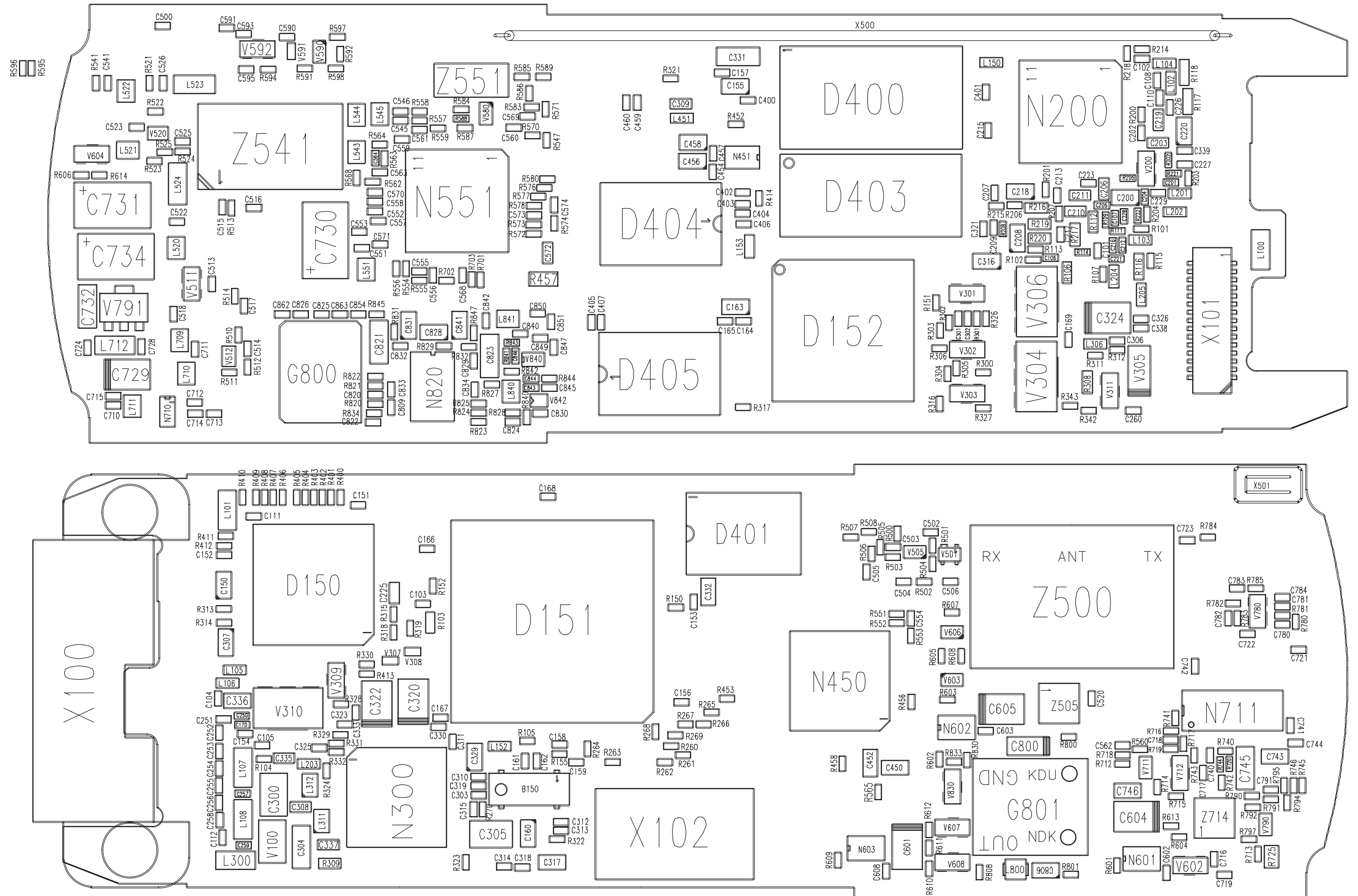

Block Diagram of Baseband (GJ8A) (Version: 3.5 ; Edit : 169) for layout version 02

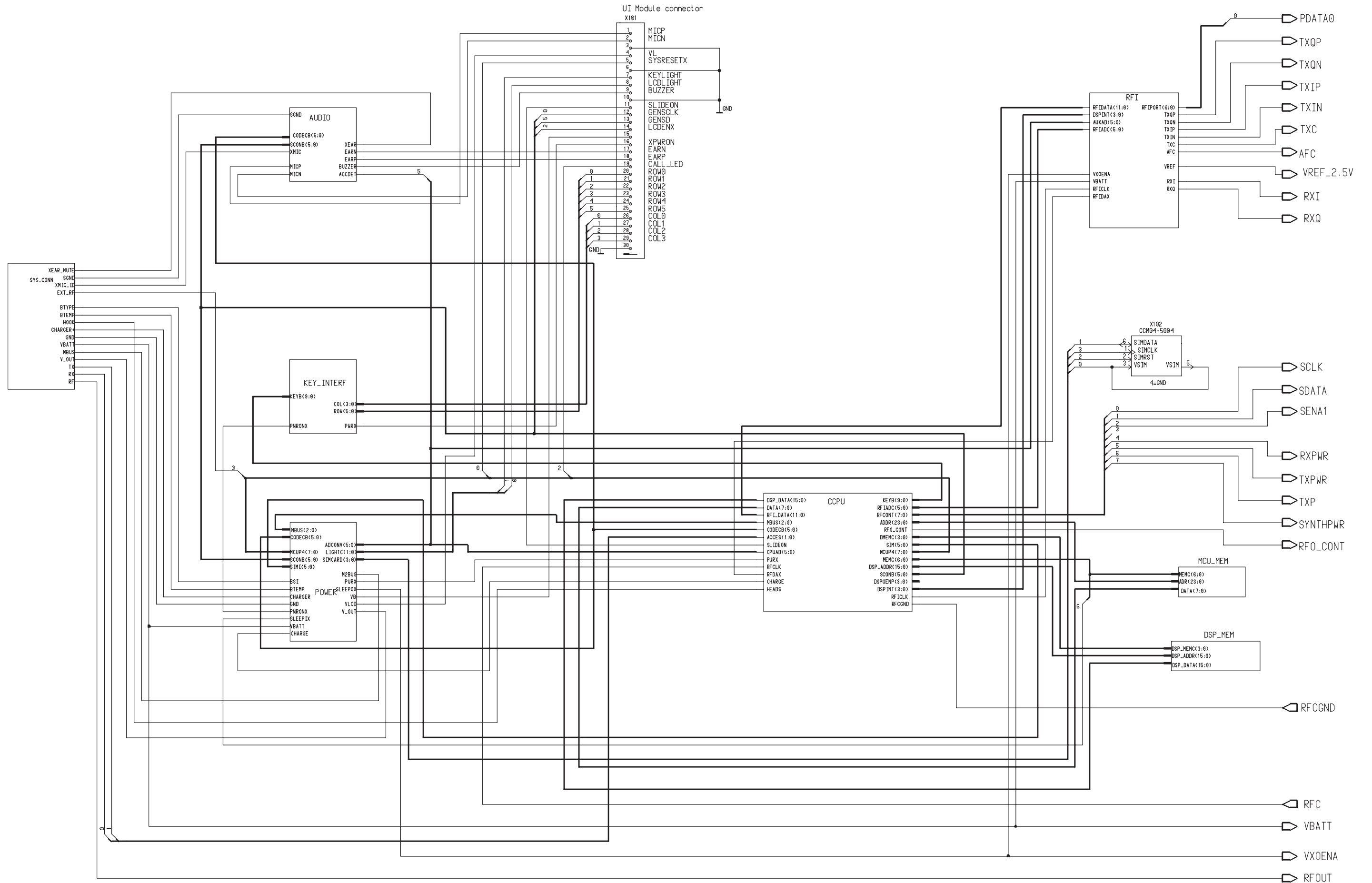

Circuit Diagram of Power Supply & Charging (GJ8A) (Version: 3.5 ; Edit:127) for layout version 02

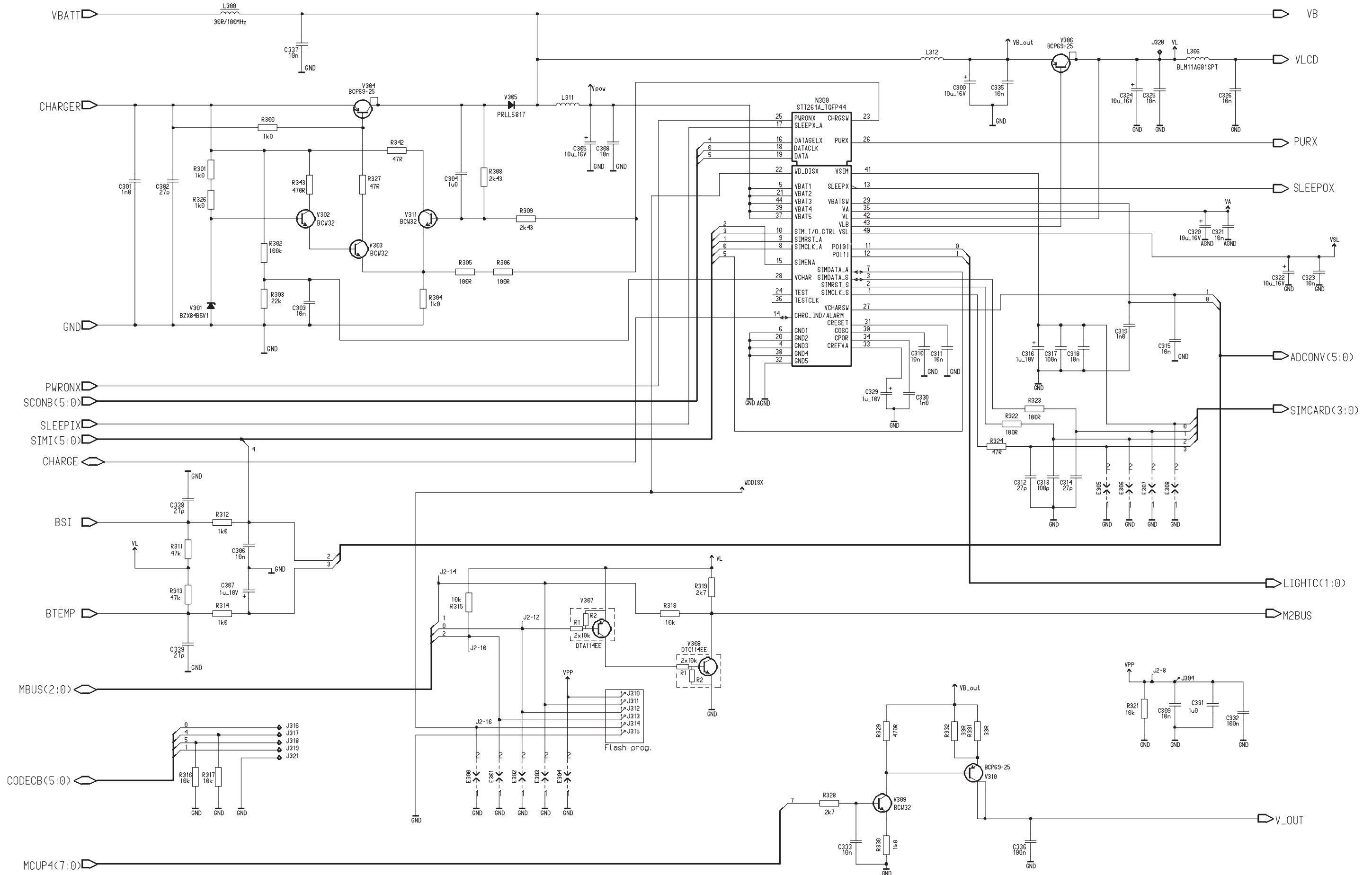

Circuit Diagram of Central Processing Unit (GJ8A) (Version: 3.5 ; Edit 149) for layout version 02

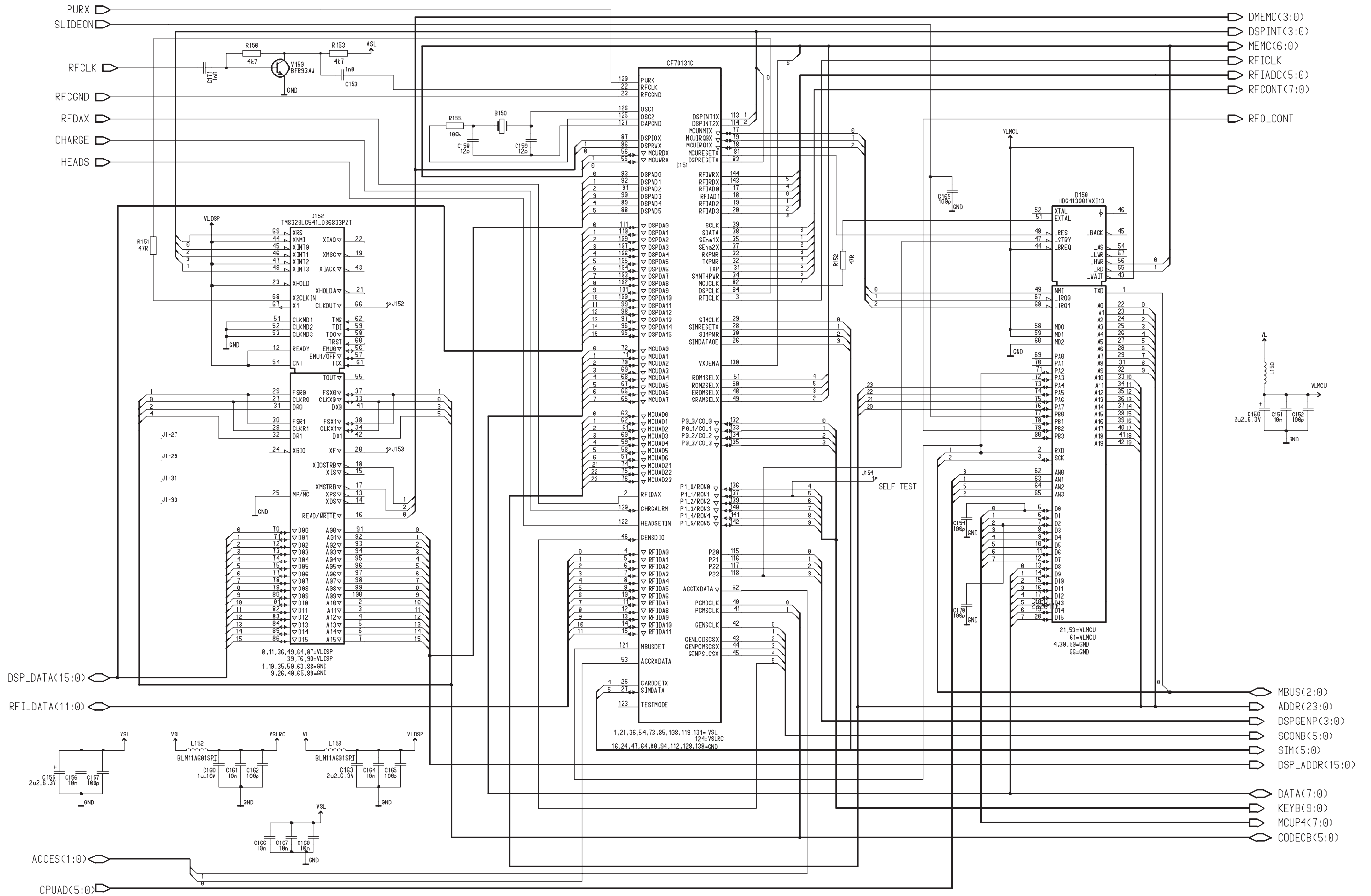

Circuit Diagram of MCU Memory Block (GJ8A) (Version: 3.5 ; Edit 55) for layout version 02

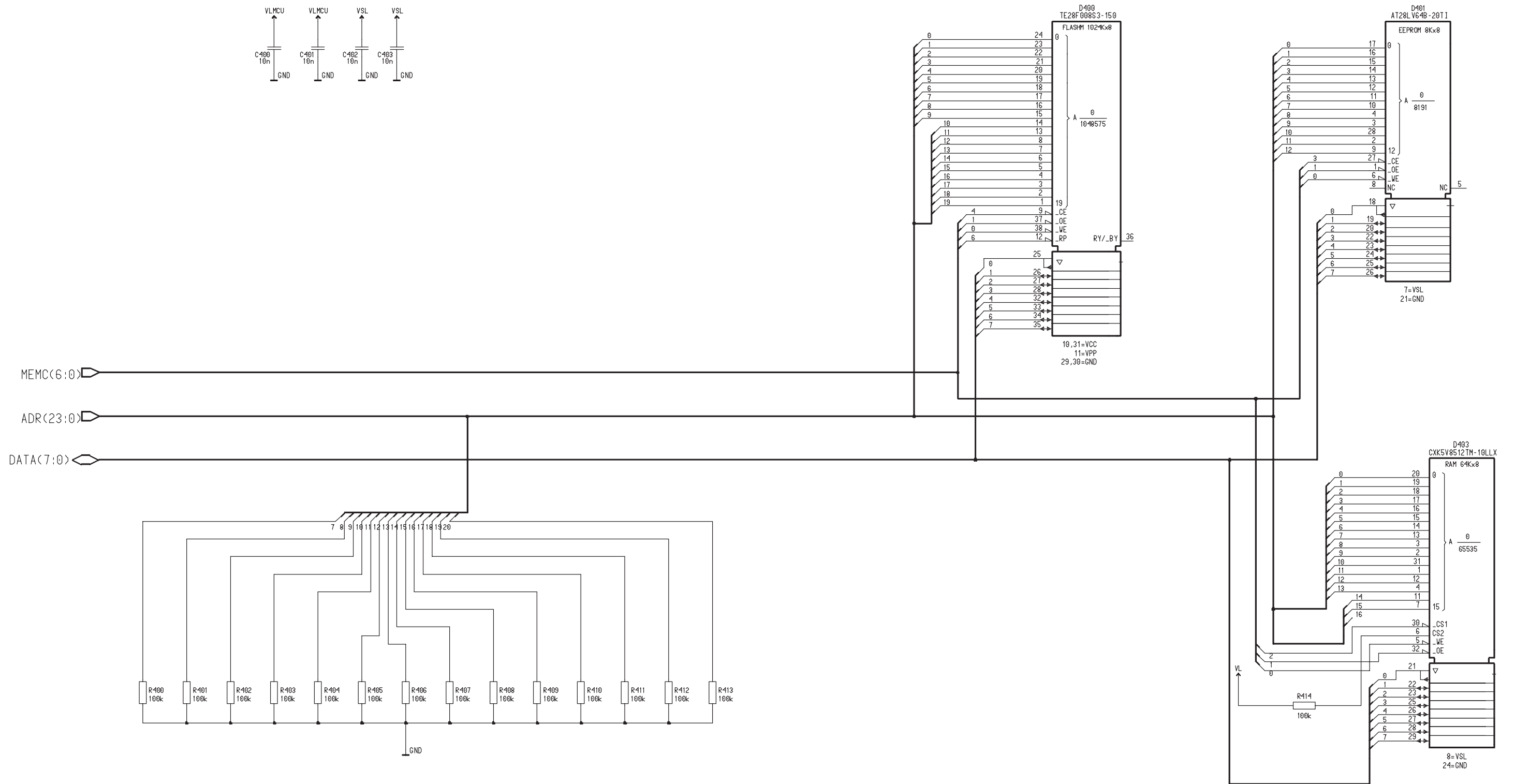

Circuit Diagram of Keyboard and Display Interface (GJ8A) (Version: 3.5 ; Edit 47) for layout version 02

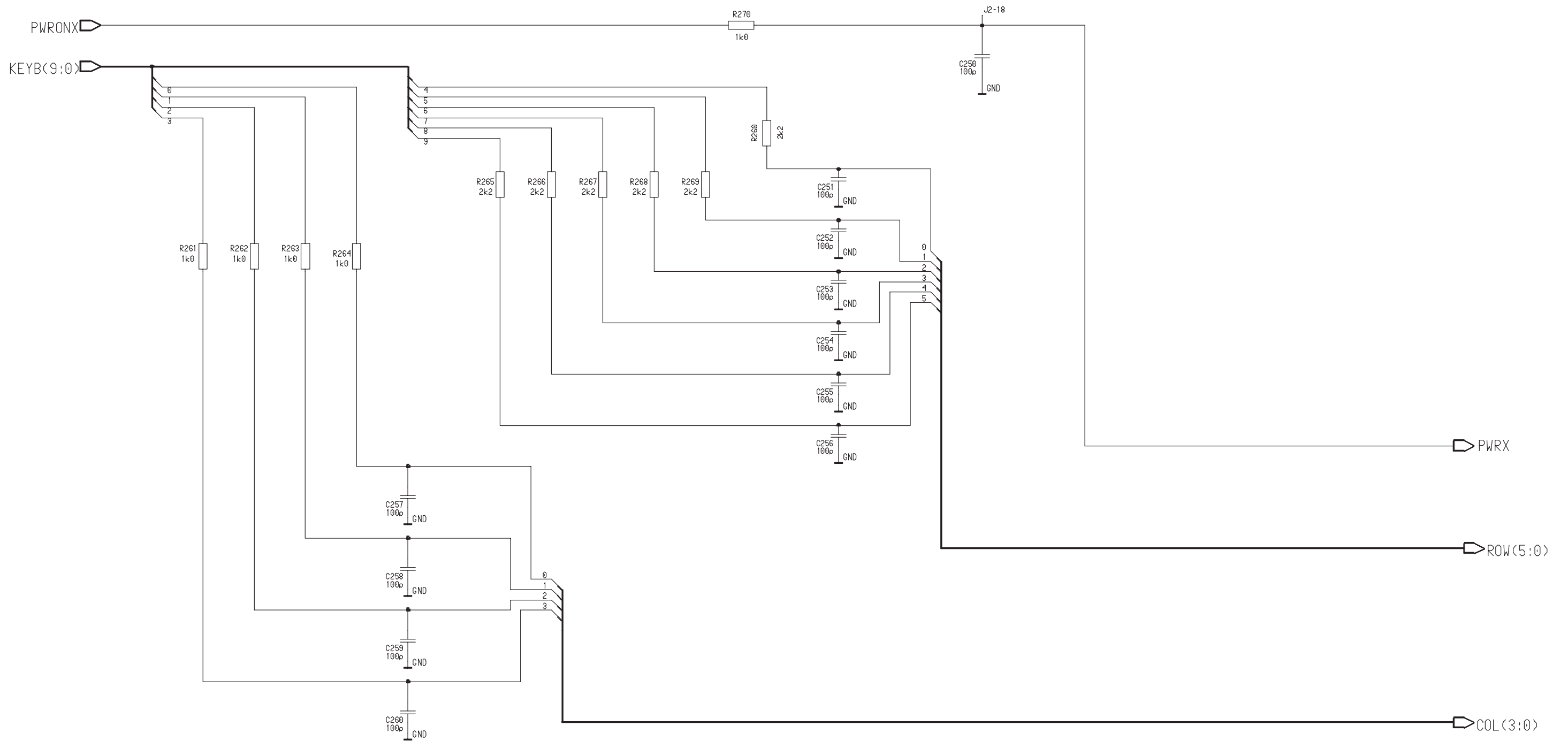

Circuit Diagram of Audio (GJ8A) (Version: 3.5 ; Edit 89) for layout version 02

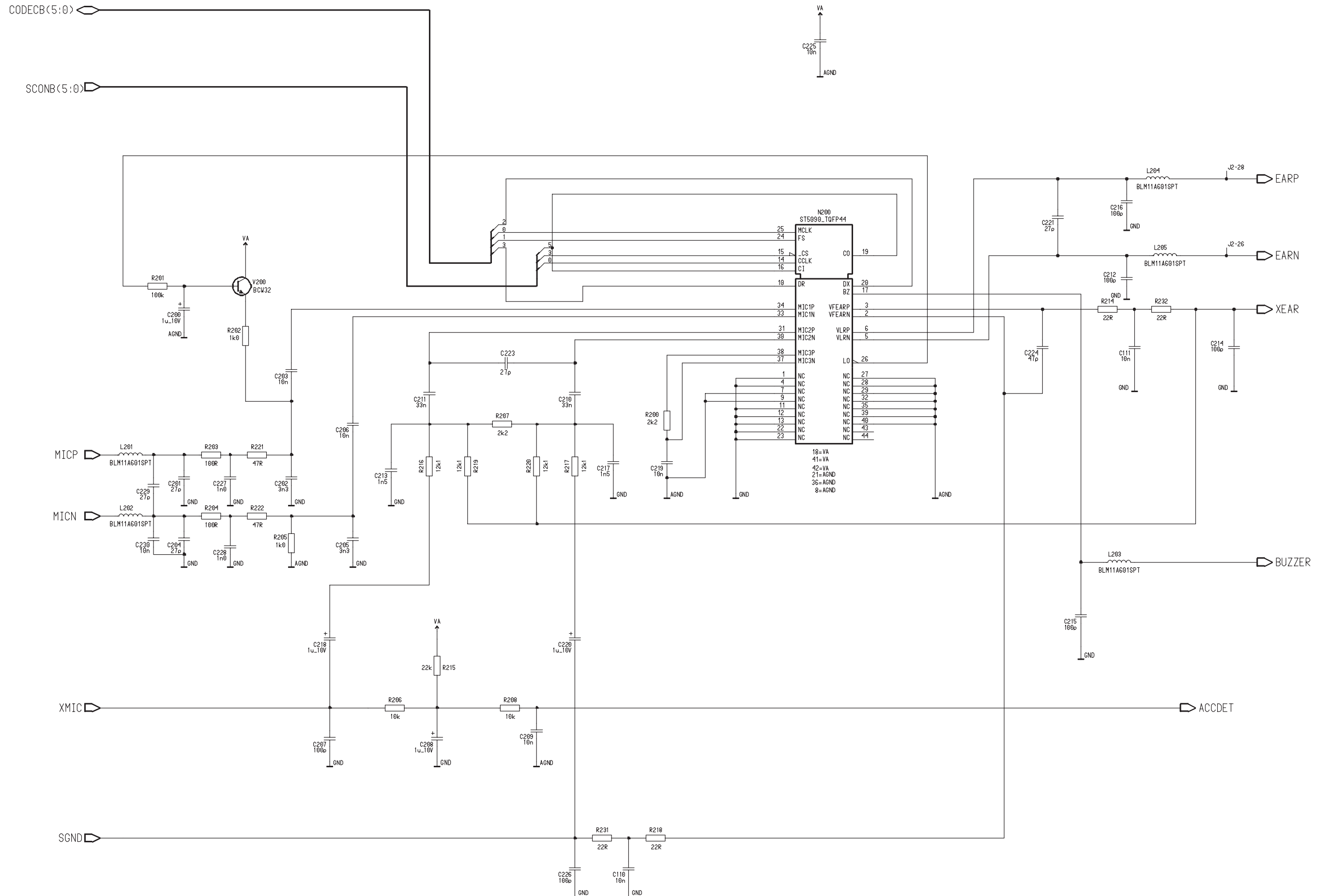

Circuit Diagram of DSP Memory Block (GJ8A) (Version: 3.5 ; Edit 46) for layout version 02

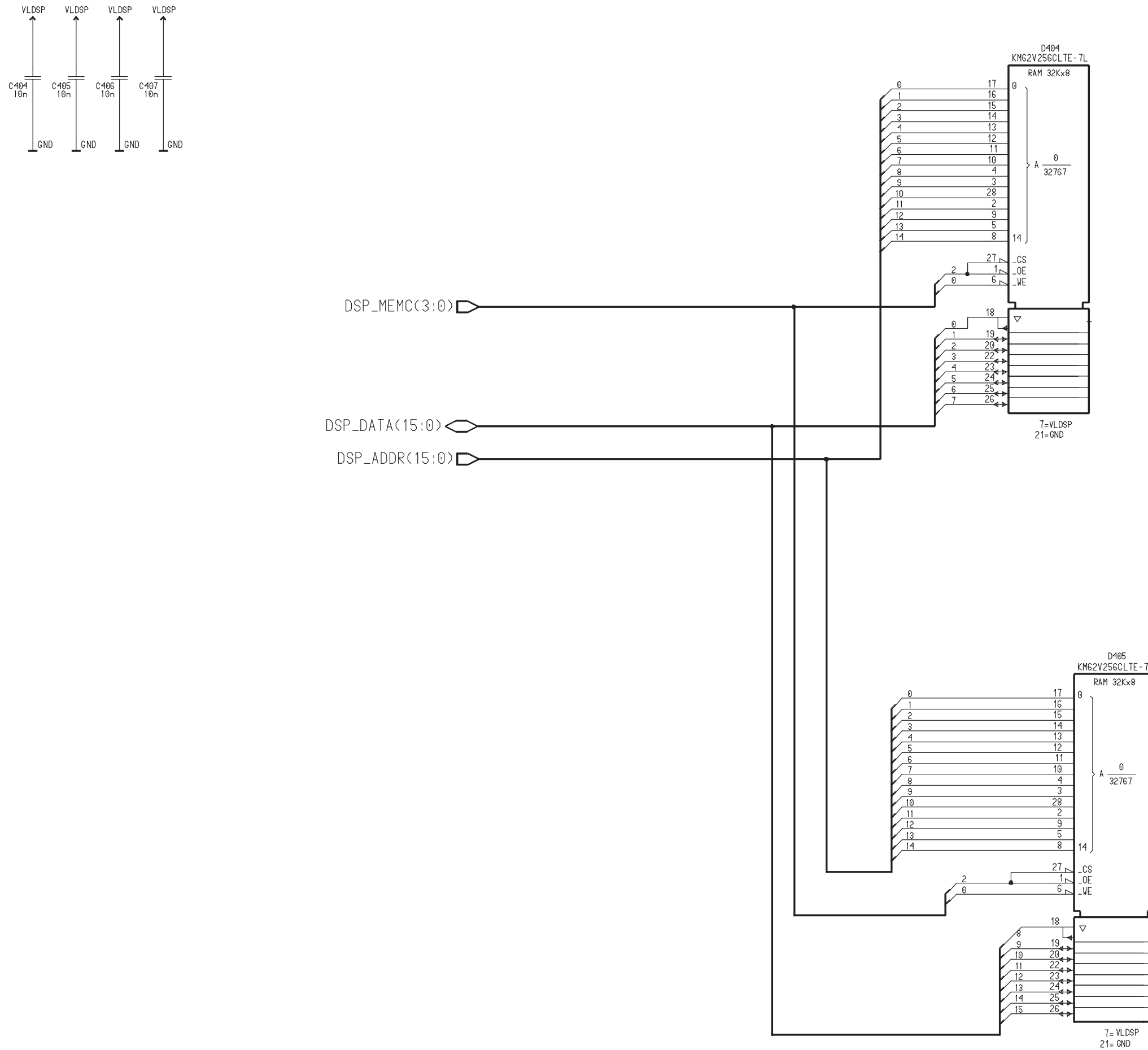

Circuit Diagram of RFI (GJ8A) (Version: 3.5 ; Edit 94) for layout version 02

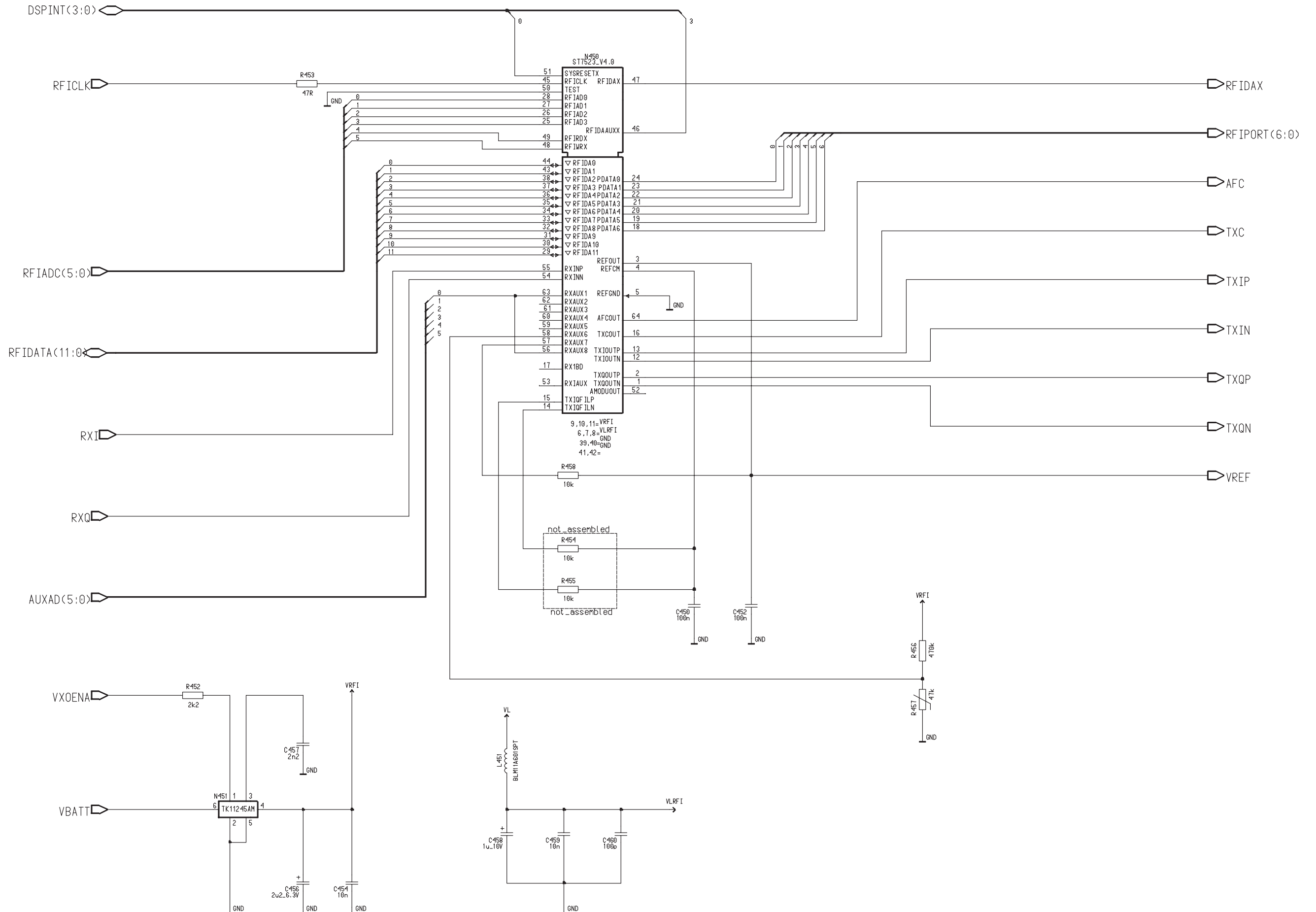

Circuit Diagram of Receiver (GJ8A) (Version: J22.7A ; Edit 344) for layout version 02

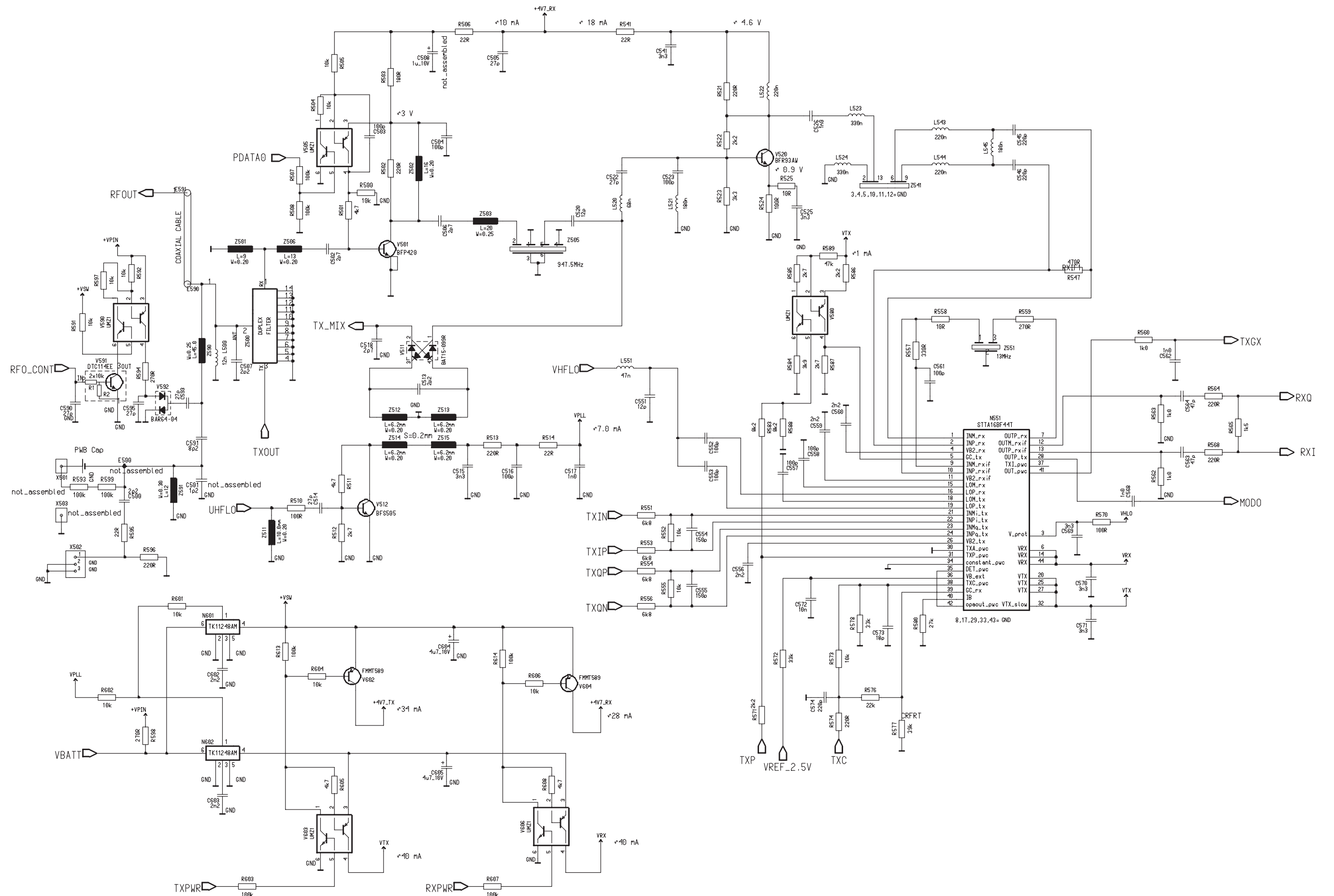

Circuit Diagram of Transmitter (GJ8A) (Version: J22.7A ; Edit 360) for layout version 02

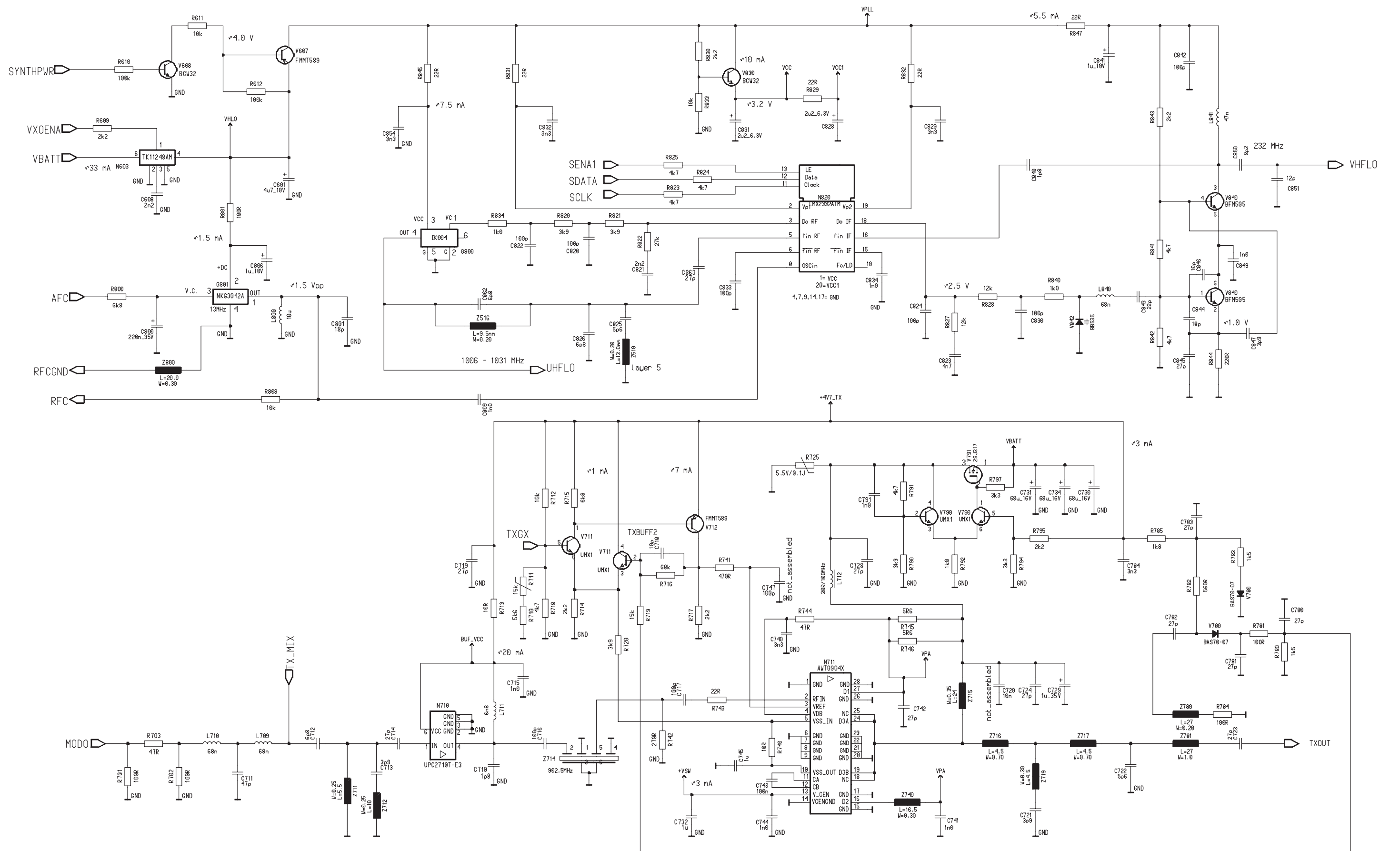

Circuit Diagram of System Connector (GJ8A) (Version: 3.5 ; Edit 96) for layout version 02

